

LMS Adaptive Receiver for Uplink Space-Time Coded MC-CDMA Systems

Bangwon Seo and Jae Young Ahn

Electronics and Telecommunications Research Institute (ETRI)
Mobile Telecommunication Research Division, Daejeon, Korea

Abstract—In this paper, we propose a least mean square (LMS) adaptive receiver for uplink multicarrier code-division multiple access (MC-CDMA) systems employing Alamouti's simple space-time block coding (STBC). In general, for the space-time coded systems, there are two filters to be designed, where one is for detecting odd-indexed symbols and the other for even-indexed symbols. In the proposed scheme, the two filters are independently updated and convergence properties such as convergence condition, time constant, and steady-state excess mean-squared error (MSE) are analyzed. Simulation results show that the proposed LMS adaptive receiver has higher steady-state signal to interference and noise ratio (SINR) than the LMS adaptive receiver for the MC-CDMA system with single transmit antenna while the former shows slower convergence rate than the latter.

Index Terms—MC-CDMA, uplink, LMS algorithm, convergence analysis.

I. INTRODUCTION

Support for very high data rate transmission is one of the key requirements for the next wireless communication standards such as IEEE 16m and 3GPP. In very high data rate transmission scenario, single carrier code-division multiple access (CDMA) systems have some critical problems such as the difficulty of synchronization and the severe inter-chip and inter-symbol interferences due to the multipath fading channels.

Recently, multicarrier transmission schemes such as orthogonal frequency-division multiplexing (OFDM), multicarrier CDMA (MC-CDMA) and multicarrier direct-sequence (MC-DS)-CDMA have been considered as a potential candidate for the next-generation high data rate wireless systems [1]. Each multicarrier transmission scheme has both advantages and disadvantages in comparison with the others. In this paper, we consider MC-CDMA systems.

MC-CDMA system is a combination of frequency-domain spreading and OFDM. An available bandwidth is decomposed into a set of disjoint equal bandwidth of small size, each sub-band signal experiences only frequency-flat fading channel and therefore, MC-CDMA systems are more robust to the distortion

induced by time-dispersive channels than single carrier CDMA systems.

It is well-known that the simple space-time block code (STBC) proposed by Alamouti in [2] offers maximum diversity gain. It has been adopted as one of the key technologies for obtaining the transmit diversity gain in the third generation communication standards [3], [4]. In case of employing Alamouti's STBC, two consecutive symbols are simultaneously transmitted using two transmit antennas at the first symbol time and their conjugated symbols with or without sign change are transmitted at the next symbol time. Therefore, two filters need to be designed for detection in which one is for detecting odd-indexed symbols and the other for even-indexed symbols.

Multiuser interference (MUI) is one of the main causes of the performance degradation for the CDMA-based transmission systems. For last two decades, there has been a lot of research on multiuser receivers. The multiuser receivers can be categorized into two types: optimal receivers and suboptimal receivers. Since the optimal receivers require too much complexity, they are not realistic. On the contrary, the suboptimal receivers have been attracted due to their low complexity. Among them, minimum mean-squared error (MMSE) receiver is one of the most popular ones, in which filter coefficients are designed to minimize the MSE.

Batch-processed multiuser receivers for DS-SS or MC-CDMA systems employing STBC have been proposed in [5], [6], and [7]. In general, the batch-processed receivers require the estimation of the inverse autocorrelation matrix of the extended received signal. However, calculating the inverse autocorrelation matrix in batch algorithm requires too much computation complexity especially when the length of the filter weight vector is large. Moreover, it is very difficult to accurately estimate the inverse autocorrelation matrix in most cases because it varies as the channel coefficients or the configuration of the users change. Therefore, it is more appropriate to implement receivers adaptively. Among the adaptive receivers, LMS-type adaptive receivers have attracted a lot of attention due to its very low complexity.

In this paper, we propose a simple LMS adaptive receiver for uplink STBC MC-CDMA and analyze its convergence properties

The paper is organized as follows. Section II describes system model and the proposed LMS adaptive receiver is proposed in Section III. Simulation results are given in Section IV and

This work was supported by the IT R&D program of MKE/NIPA in Korea. [2006-S001-03, Development of adaptive radio access and transmission technologies for 4th generation mobile communications]

Section V concludes the paper.

II. SYSTEM MODEL

Fig. 1 shows the transmitter structure of user k for uplink STBC MC-CDMA system considered in this paper. We consider two transmit antennas and one receive antenna for simplicity. For every two symbols, the space-time block coding is applied. Therefore, at the first symbol interval, $d_k(2i-1)$ and $d_k(2i)$ are transmitted using the transmit antennas 1 and 2, respectively, and at the next symbol interval, $d_k^*(2i-1)$ and $-d_k^*(2i)$ are sent. In addition, a spreading code pair $(\mathbf{s}_{k,1}, \mathbf{s}_{k,2})$ is used in the transmit antennas 1 and 2 for frequency-domain spreading where $\mathbf{s}_{k,m}$ is given by

$$\mathbf{s}_{k,m} = [s_{k,m,1}, s_{k,m,2}, \dots, s_{k,m,N}]^T. \quad (1)$$

Then, an N -point IFFT operation is performed where N is the number of subcarriers. It is assumed that the number of subcarriers is equal to the processing gain of the spreading code. The IFFT output signal is parallel-to-serial converted, inserted by the cyclic prefix, and then transmitted through the channel.

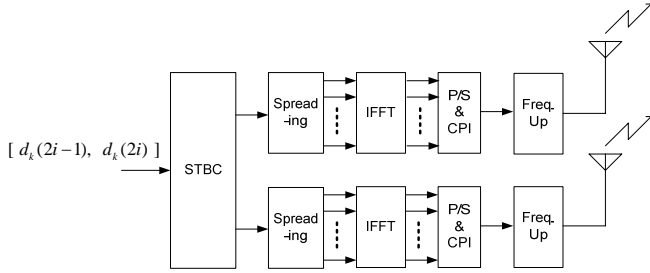

Fig. 1. Transmitter structure for MC-CDMA system employing STBC

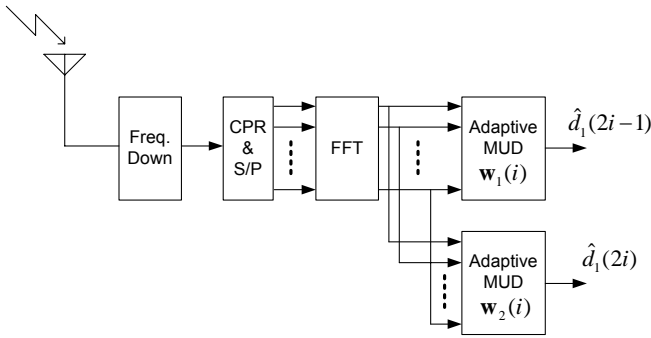

Fig. 2. Receiver structure for MC-CDMA system employing STBC

Fig. 2 shows the receiver structure. At the receiver, the cyclic prefix is removed from the received signal and the resulting signal is serial-to-parallel converted, and then performed by the N -point FFT operation. Assuming that the maximum delay spread is less than the cyclic prefix length for all users, the

frequency-domain received signal vector after FFT operation is written as

$$\begin{aligned} \mathbf{r}(2i-1) &= \sum_{k=1}^K \{ \mathbf{H}_{k,1} \mathbf{s}_{k,1} d_k(2i-1) + \mathbf{H}_{k,2} \mathbf{s}_{k,2} d_k(2i) \} + \mathbf{z}(2i-1) \\ \mathbf{r}(2i) &= \sum_{k=1}^K \{ -\mathbf{H}_{k,1} \mathbf{s}_{k,1} d_k^*(2i) + \mathbf{H}_{k,2} \mathbf{s}_{k,2} d_k^*(2i-1) \} + \mathbf{z}(2i) \end{aligned} \quad (2)$$

where $\mathbf{H}_{k,m}$ is the frequency-domain channel response from the transmit antenna m of user k given by

$$\mathbf{H}_{k,m} = \text{diag}(H_{k,m,0}, H_{k,m,1}, \dots, H_{k,m,N-1}) \quad (3)$$

and $\mathbf{z}(l)$ is the complex additive white Gaussian noise (AWGN) with mean $\mathbf{0}$ and covariance matrix $\sigma_z^2 \mathbf{I}_{2N}$ where \mathbf{I}_{2N} is an identity matrix of size $2N \times 2N$. The l -th information data of user k , $d_k(l)$, is an independent and identically distributed (*i. i. d.*) random variable with zero mean and unit variance.

If we define the effective spreading code at the transmit antenna m of user k by $\mathbf{c}_{k,m}$, the received signal vector can be rewritten as

$$\begin{aligned} \mathbf{r}(2i-1) &= \sum_{k=1}^K \{ \mathbf{c}_{k,1} d_k(2i-1) + \mathbf{c}_{k,2} d_k(2i) \} + \mathbf{z}(2i-1) \\ \mathbf{r}(2i) &= \sum_{k=1}^K \{ -\mathbf{c}_{k,1} d_k^*(2i) + \mathbf{c}_{k,2} d_k^*(2i-1) \} + \mathbf{z}(2i) \end{aligned} \quad (4)$$

III. BATCH-PROCESSED RECEIVER

Defining the extended received signal vector for the two consecutive symbols by $\mathbf{y}(i)$ yields

$$\begin{aligned} \mathbf{y}(i) &= [\mathbf{r}^T(2i-1) \ \mathbf{r}^H(2i)]^T \\ &= \sum_{k=1}^K \{ \mathbf{g}_{k,1} d_k(2i-1) + \mathbf{g}_{k,2} d_k(2i) \} + \mathbf{v}(i) \end{aligned} \quad (5)$$

where $\mathbf{g}_{k,m}$ and $\mathbf{v}(i)$ are given by

$$\mathbf{g}_{k,1} = \begin{bmatrix} \mathbf{c}_{k,1} \\ \mathbf{c}_{k,2}^* \end{bmatrix}, \quad \mathbf{g}_{k,2} = \begin{bmatrix} \mathbf{c}_{k,2} \\ -\mathbf{c}_{k,1}^* \end{bmatrix}, \quad \mathbf{v}(i) = \begin{bmatrix} \mathbf{z}(2i-1) \\ \mathbf{z}^*(2i) \end{bmatrix} \quad (6)$$

, respectively. Assuming that the desired user is user 1 and defining $\mathbf{G}_1 = [\mathbf{g}_{1,1} \ \mathbf{g}_{1,2}]$ and $\mathbf{d}_1(i) = [d_1(2i-1) \ d_1(2i)]^T$, the extended received signal vector $\mathbf{y}(i)$ is rewritten as

$$\mathbf{y}(i) = \mathbf{G}_1 \mathbf{d}_1(i) + \mathbf{u}(i) \quad (7)$$

where $\mathbf{u}(i)$ denotes the MUI plus AWGN given by

$$\mathbf{u}(i) = \sum_{k=2}^K \left\{ \mathbf{g}_{k,1} d_k(2i-1) + \mathbf{g}_{k,2} d_k(2i) \right\} + \mathbf{v}(i). \quad (8)$$

If we define the filter weight vectors \mathbf{w}_1 and \mathbf{w}_2 of size $2N \times 1$ for detecting $d_k(2i-1)$ and $d_k(2i)$, respectively, the mean-squared error (MSE) at the filter output is given by

$$\begin{aligned} J(\mathbf{w}_1, \mathbf{w}_2) &= E \left[\left| \mathbf{W}^H \mathbf{y}(i) - \mathbf{d}_1(i) \right|^2 \right] \\ &= E \left[\left| \mathbf{w}_1^H \mathbf{y}(i) - d_1(2i-1) \right|^2 \right] + E \left[\left| \mathbf{w}_2^H \mathbf{y}(i) - d_1(2i) \right|^2 \right] \\ &= J_1(\mathbf{w}_1) + J_2(\mathbf{w}_2) \end{aligned} \quad (9)$$

where $\mathbf{W} = [\mathbf{w}_1 \ \mathbf{w}_2]$ and

$$\begin{aligned} J_1(\mathbf{w}_1) &= E \left[\left| \mathbf{w}_1^H \mathbf{y}(i) - d_1(2i-1) \right|^2 \right] \\ J_2(\mathbf{w}_2) &= E \left[\left| \mathbf{w}_2^H \mathbf{y}(i) - d_1(2i) \right|^2 \right] \end{aligned} \quad (10)$$

The MMSE receiver for STBC MC-CDMA is obtained by solving the following optimization problem [6]:

$$\begin{aligned} [\mathbf{w}_{1,opt}, \mathbf{w}_{2,opt}] &= \arg \min_{\mathbf{w}_1, \mathbf{w}_2} J(\mathbf{w}_1, \mathbf{w}_2) \\ &= \arg \left\{ \min_{\mathbf{w}_1} J_1(\mathbf{w}_1) + \min_{\mathbf{w}_2} J_2(\mathbf{w}_2) \right\}. \end{aligned} \quad (11)$$

The gradient for \mathbf{w}_m^* is given by

$$\frac{\partial}{\partial \mathbf{w}_m^*} J(\mathbf{w}_1, \mathbf{w}_2) = \frac{\partial}{\partial \mathbf{w}_m^*} J_m(\mathbf{w}_m) = E[e_m^*(i) \mathbf{y}(i)] \quad (12)$$

$$= \mathbf{R}_y \mathbf{w}_m - \mathbf{g}_{1,m}, \quad m = 1, 2 \quad (13)$$

where \mathbf{R}_y is autocorrelation matrix given by

$$\mathbf{R}_y = \sum_{k=1}^K \left\{ \mathbf{g}_{k,1} \mathbf{g}_{k,1}^H + \mathbf{g}_{k,2} \mathbf{g}_{k,2}^H \right\} + \sigma_z^2 \mathbf{I}_{2N} \quad (14)$$

and the filter output errors are given by

$$e_m(i) = \begin{cases} \mathbf{w}_1^H \mathbf{y}(i) - d_1(2i-1), & \text{if } m=1 \\ \mathbf{w}_2^H \mathbf{y}(i) - d_1(2i), & \text{if } m=2 \end{cases}. \quad (15)$$

By setting the gradient to zero, the MMSE filter weight vectors for STBC MC-CDMA systems are given by

$$\mathbf{w}_{1,opt} = \mathbf{R}_y^{-1} \mathbf{g}_{1,1}, \quad \mathbf{w}_{2,opt} = \mathbf{R}_y^{-1} \mathbf{g}_{1,2}. \quad (16)$$

The minimum MSE is given by

$$J_{\min} = J(\mathbf{w}_{1,opt}, \mathbf{w}_{2,opt}) = J_{1,\min} + J_{2,\min} \quad (17)$$

where $J_{1,\min}$ and $J_{2,\min}$ are given by

$$\begin{aligned} J_{1,\min} &= 1 - \mathbf{g}_{1,1}^H \mathbf{R}_y^{-1} \mathbf{g}_{1,1} \\ J_{2,\min} &= 1 - \mathbf{g}_{1,2}^H \mathbf{R}_y^{-1} \mathbf{g}_{1,2} \end{aligned} \quad (18)$$

It is well known that the MMSE receiver maximizes the signal to interference and noise ratio (SINR). Therefore, the maximum SINR averaged for the two symbols is obtained when $\mathbf{w}_{1,opt}$ and $\mathbf{w}_{2,opt}$ are used and it is given by

$$\text{SINR}_{opt} = \frac{1}{2} \left\{ \frac{\mathbf{g}_{1,1}^H \mathbf{R}_y^{-1} \mathbf{g}_{1,1}}{1 - \mathbf{g}_{1,1}^H \mathbf{R}_y^{-1} \mathbf{g}_{1,1}} + \frac{\mathbf{g}_{1,2}^H \mathbf{R}_y^{-1} \mathbf{g}_{1,2}}{1 - \mathbf{g}_{1,2}^H \mathbf{R}_y^{-1} \mathbf{g}_{1,2}} \right\}. \quad (19)$$

IV. LMS ADAPTIVE RECEIVER

A. Proposed Adaptive Receiver

From (16), it can be observed that the batch-process MMSE receiver requires the estimation of the inverse matrix of the autocorrelation matrix \mathbf{R}_y of the extended received signal $\mathbf{y}(i)$. In order to estimate \mathbf{R}_y^{-1} , however, the receiver should have an information on the spreading codes and channel of all users and it is not available in most cases. Moreover, the autocorrelation matrix changes as the user configuration or channel varies and the inverse matrix should be re-calculated. Since the size of the autocorrelation is very large in general, it needs a lot of computation complexity to calculate \mathbf{R}_y^{-1} . Therefore, it is more appropriate to implement receivers adaptively. Among the adaptive receivers, the LMS-type adaptive receiver is more attractive due to its very low complexity. Therefore, we propose an LMS-type adaptive receiver appropriate for the STBC MC-CDMA system.

From (10) and (11), it can be observed that $\mathbf{w}_m(i)$ affects $J_m(\mathbf{w}_m)$ only in $J(\mathbf{w}_1, \mathbf{w}_2)$. Therefore, a simple adaptive LMS adaptive receiver for STBC MC-CDMA system is to update $\mathbf{w}_1(i)$ and $\mathbf{w}_2(i)$, independently. The adaptive receiver is obtained by replacing the gradient for $\mathbf{w}_m(i)$ given in (12) with its sample mean, *i.e.*,

$$\frac{\partial}{\partial \mathbf{w}_m^*} J(\mathbf{w}_1, \mathbf{w}_2) = E[e_m^*(i) \mathbf{y}(i)] \approx e_m^*(i) \mathbf{y}(i). \quad (20)$$

Therefore, the proposed LMS adaptive receiver is given by

$$\mathbf{w}_m(i+1) = \mathbf{w}_m(i) - \mu e_m^*(i) \mathbf{y}(i), \quad m=1,2 \quad (21)$$

where μ is a step size.

B. Convergence Analysis

In this subsection, we analyze the convergence properties of the proposed LMS adaptive receiver for STBC MC-CDMA system.

From (17) and (13), it can be seen that the update equation of the adaptive receiver has the similar form as given in [8, equation (5.8)]. Therefore the convergence analysis results can be easily obtained following the similar procedure as given in [8].

The LMS adaptive receiver converges in the mean sense if the independence assumption between $\mathbf{w}_m(i)$ and $\mathbf{y}(i)$, and the following step size condition are satisfied [8]

$$0 < \mu < \frac{2}{\lambda_{\max}} \quad (22)$$

where λ_{\max} is the largest eigenvalue of \mathbf{R}_y .

The ensemble-average learning curve of the LMS-type adaptive receiver can be approximated by a single exponential. The time constant is defined as the number of iterations required for the ensemble average learning curve in the LMS filter to decay to $1/e$ of its initial value [8]. It can be used as a measure for convergence rate of the LMS adaptive receiver.

The time constant for the LMS adaptive receiver is given by

$$\tau_{\text{av}} \approx \frac{1}{\mu \lambda_{\text{av}}} = \frac{1}{\mu \cdot \text{tr}(\mathbf{R}_y)} \quad (23)$$

where $\lambda_{\text{av}} = \sum_{l=1}^{2N} \lambda_l$ and λ_l is the eigenvalue of \mathbf{R}_y .

The steady-state excess MSE for the LMS adaptive receiver is simply the sum of the steady-state excess MSEs for $J_1(\mathbf{w}_1)$ and $J_2(\mathbf{w}_2)$ given by

$$\begin{aligned} J_{\text{ex}}(\infty) &= J_{1,\text{ex}}(\infty) + J_{2,\text{ex}}(\infty) \\ &= \frac{\mu}{2} J_{\min} \sum_{k=1}^{2N} \lambda_k = \frac{\mu}{2} J_{\min} \text{tr}(\mathbf{R}_y) \end{aligned} \quad (24)$$

The misadjustment is defined as the ratio between the steady-state excess MSE and the minimum MSE. Therefore, the misadjustment M for the LMS adaptive receiver is given by

$$M = \frac{J_{\text{ex}}(\infty)}{J_{\min}} = \frac{\mu}{2} \text{tr}(\mathbf{R}_y). \quad (25)$$

V. SIMULATION RESULTS

We consider an uplink MC-CDMA system employing the Alamouti's STBC. The number of subcarriers is $N = 32$ and it is equal to the length of the spreading sequence. The complex random spreading sequence is used for each user and the values of its real and imaginary parts are independently and randomly taken from $1/\sqrt{2}$ and $-1/\sqrt{2}$ with equal probability.

Rayleigh multipath fading channels with three paths is used for each user. The fading gains are generated by using a complex Gaussian distribution, which are normalized such that the average energy of the channel is unity. The spreading sequences and channel coefficients are fixed over all simulation runs. The simulation results are averaged for 200 independent runs.

The Fig. 2 shows the MSE learning curves when the signal to noise ratio (SNR) is 25dB and the number of user is $K=10$. In the figure, green and red lines represent the proposed adaptive receiver with step sizes $\mu_p = 0.02$ and $\mu_p = 0.01$, respectively, and blue and light blue lines denote the general LMS adaptive receiver for MC-CDMA system with single transmit antenna with step sizes $\mu_{\text{tx}} = 0.02$ and $\mu_{\text{tx}} = 0.01$, respectively.

From the figure, it can be seen that the proposed adaptive receiver has lower MSE than the single antenna case for the same step size parameter while the convergence rate of the proposed adaptive receiver is slower than the single antenna case. The slow convergence rate property of the proposed scheme can be explained as follows. In the proposed scheme, the received signals $\mathbf{y}(i)$ for the two consecutive symbols are processed together at the filter and therefore the filter tap length of the proposed adaptive receiver is two times longer than that of the single transmit antenna MC-CDMA system. Since the convergence rate in the LMS-type adaptive receiver is inversely proportional to the filter tap length [9], [10], the convergence rate of the proposed scheme is slower than that of the single transmit antenna MC-CDMA system.

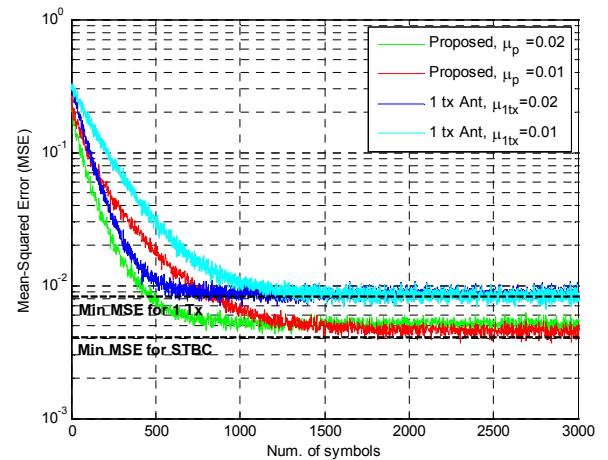

Fig. 2. MSE learning curves for the proposed scheme and general single transmit antenna scheme

The Fig. 3 shows the filter output SINR performance averaged every two consecutive symbols when SNR=25dB and $K=20$. In the figure, the proposed adaptive receiver has 3dB higher steady-state SINR performance than the general LMS adaptive receiver for MC-CDMA systems with single transmit antenna.

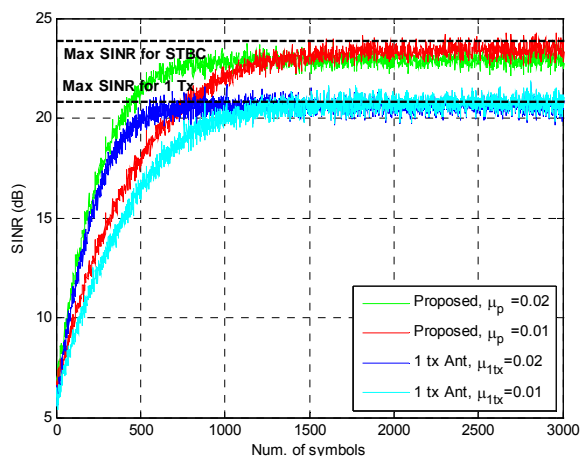

Fig. 3. SINR comparison between the proposed scheme and single antenna case

VI. CONCLUSION

We proposed a simple LMS adaptive receiver for uplink MC-CDMA systems employing Alamouti's simple STBC scheme and analyzed the convergence properties. The proposed adaptive receiver shows 3dB higher steady-state SINR performance than the general LMS adaptive receiver for MC-CDMA systems with single transmit antenna for the same step size parameter while the convergence rate of the proposed receiver is slower than the latter. Therefore, the proposed adaptive receiver is more attractive for the systems in which the steady-state SINR property of the filter is more important than the convergence rate.

REFERENCES

- [1] S. Hara and R. Prasad, "Overview of multicarrier CDMA," *IEEE Commun. Mag.*, Vol. 35, pp. 126-133, Dec. 1997.
- [2] S. Alamouti, "A simple transmit diversity technique for wireless communications," *IEEE J. Select. Areas Commun.*, Vol. 16, pp. 1451-1458, Oct. 1998.
- [3] 3GPP Technical Specification 36.211 V8.6.0, "Evolved universal terrestrial radio access: Physical channels and modulation," Mar. 2009.
- [4] S. Verdu, *Multuser Detection*, Cambridge, U. K.: Cambridge Univ. Press, 1998.
- [5] Z. Li and M. Latva-aho, "Nonblind and semibind space-time frequency multiuser detection for space-time block coded MC-CDMA," *IEEE Trans. Wireless Commun.*, Vol. 4, pp. 1311-1318, July, 2005.
- [6] J. L. Yu and I.-T. Lee, "MIMO capon receiver and channel estimation for space-time coded CDMA systems," *IEEE Trans. Wireless Commun.*, Vol. 5, pp. 3023-3028, Nov. 2006.
- [7] H. Li, X. Lu, and G. B. Giannakis, "Capon multiuser receiver for CDMA systems with space-time coding," *IEEE Trans. Signal Processing*, Vol. 50, pp. 1193-1204, May, 2002.
- [8] S. Haykin, *Adaptive Filter Theory*, 4th ed. Prentice Hall, 2002.
- [9] K. Shi, X. Ma, and Z. Tong Zhou, "A variable step size and variable tap length LMS algorithm for impulse responses with exponential profile," *Proc. IEEE ICASSP*, pp. 3105-3108, 2009.
- [10] Y. Gu, K. Tang, H. Cui, and W. Du, "Convergence analysis of a deficient-length LMS filter and optimal-length sequence to model exponential decay impulse response," *IEEE Signal Processing Letters*, Vol. 10, pp. 4-7, Jan. 2003.